



RENTAL MODULE

100 Ton

Cat®/York® air cooled screw chillers are self-contained and provide chilled water for outdoor rental air conditioning and process applications. Each unit includes: York air cooled semi-hermetic screw chiller with a weather-resistant microprocessor control center, water fittings, triple duty valves, and in-line water strainers, all mounted on a formed steel base frame that includes a heavy-duty safety wire mesh dipped in rust-protective coating for protection. This unit is reinforced with an industrial rugged, rental ready, skid mounted framing for increased durability and strength (ISO container optional). Units meet or exceed industry guidelines and third party safety and quality standards.

TECHNICAL SPECIFICATIONS

Model	CH100
Dimensions — ft (m)	
Length	14' 7" (4.45)
Width	8' (2.44)
Height	8' 9" (2.67)
Total shipping weight — lb (kg)	9,233 (4188)

Water connections — in (mm)	4 (102)
Single point power supply	460 Volt 3-phase
	60 Hertz with ground
Running load amps (with pump)	191
Minimum circuit ampacity (with pump)	209

FEATURES

COMPONENTS

- York air cooled semi-hermetic screw chiller
 - Two (2) semi-hermetic screw design compressors. One compressor per refrigerant system.
 - Evaporator equipped for freeze protection down to -20° F (-29° C) ambient.
 - Condenser coils design working pressure of the coil is 450 psig.
 - Controls housed in NEMA 3R/12 air-tight cabinet with LCD with back lighting for outdoor viewing. Forty characters in plain English terms with color-coded 12-button non-tactile keypad.
 - Provisions included for pumpdown at shutdown; unit alarm contacts standard. Operating program stored in non-volatile memory (EPROM), eliminating chiller failure due to AC powered failure/battery discharge.
 - Control transformer steps down incoming 460/3/60 power to supply 115/1/60 control power.
 - Black fin corrosion resistant coating protects condenser in harsh industrial/saltwater environments (optional feature)

- One (1) 15 hp (11.2 kW) Bell & Gossett pump integral to frame (optional feature)
 - Range 122 to 430 Gal/min (462 to 1630 L/min)
 - 250 Gal/min (948 L/min) nominal at 100 feet (30.5 m) of head pressure providing system flexibility
- Infinite position butterfly valves to dial in the evaporator bypass loop
- Insulated water and suction lines to prevent condensation

CONTROL/POWER CENTER

- Single point power supply connection with individual system circuit breakers (2 – 200 amp)
- NEMA rated motor starters for circulating pumps with manual HAND-OFF-AUTO controls for each pump
- Convenient 120 Volt outlet provides users a power supply right at the chiller.
- Power panels include: 3-light system to notify 460 Volt present, correct phase rotation, and available shore power. Compressor power terminals and motor starting contactors, fan contactors, and overload current protection. Power wiring routed through liquid tight conduit to compressors.

AIR COOLED SCREW CHILLER



DIMENSIONS

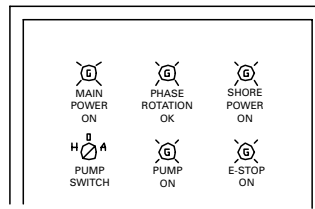
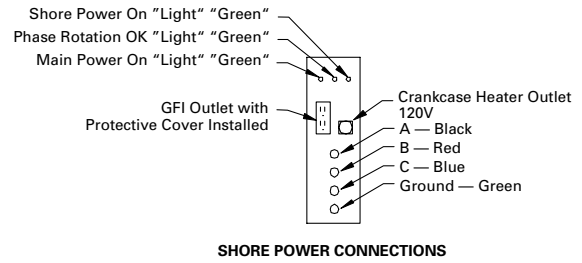
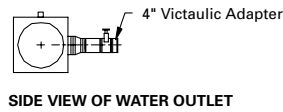
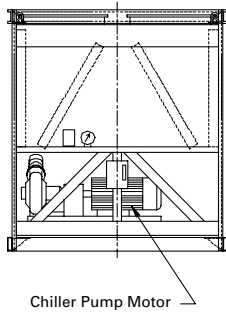
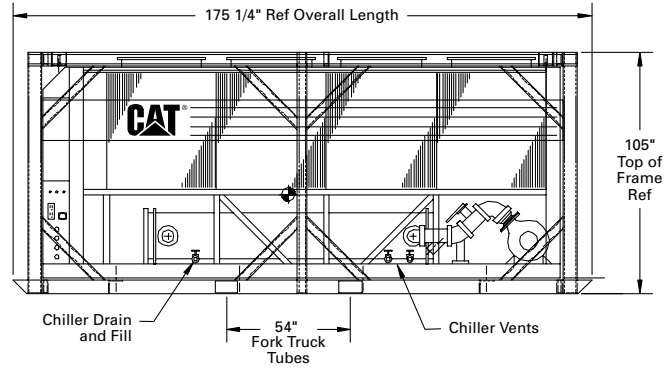
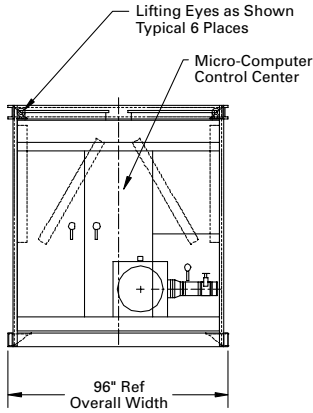

VIEW "B"
POWER DISTRIBUTION ENCLOSURE
CONTROLS LAYOUT

Consult your Caterpillar representative for more details.

www.CAT-ElectricPower.com

©2001 Caterpillar
All rights reserved.
Printed in U.S.A.